

Harmonic Attenuation of Current and Voltage Using Passive Filters in Residential Electrical Installations

Agung Herdianto

Universitas PGRI Argopuro, Jember, Jawa Timur, Indonesia
Email: agungherdianto@ikipjember.ac.id

ARTICLE INFO

Article history:
Accepted

Keywords:
Double tuned filter
High Pass Filter
Total Harmonic Distortions (THD)

ABSTRACT

The planning of electrical installation in a residential building needs to be carefully considered because of the variation of load usage, which will lead to the requirement of standard electrical installation. Improper installation will cause a failure in the protection system such as electrical shortage and a reduction in terms of the usage of electrical equipment. In this paper, a harmonic study is conducted on an electrical network that is caused by the non-linear load usage in two-story building with a size of 80 m². The study is aimed to be one of standards of electrical installation by analyzing harmonic current and voltage as well as its impact to the protection system of residential building. A type of passive filters, that are high pass filter and double tuned filter are applied to dampen the harmonic. The simulation result shows that total harmonic disorder (THD) of non-filter electrical installation has a current harmonic value of 98% and voltage harmonic of 1,3%. On the other hand, there is a significant reduction of harmonic in the electrical installation with a passive filter installed of which the current harmonic value drops to 21%.

Copyright © 2022 Politeknik Aceh Selatan.
All rights reserved.

I. Introduction

Urban areas are densely populated areas where most of the people choose to live in housing area. Residential areas are also called the areas with the second largest electricity consumption after industrial areas. Problems arise due to the massive use of non-linear electrical load variations, which is not comparable to the quality of electrical installations in housing which is under the Indonesian National Standard or better known as SNI. Linear loads are loads that have a sinusoidal waveform, while non-linear loads have non-sinusoidal waves because their harmonic currents have been distorted. Electronic equipment that has non-linear properties and is used in housing includes air conditioners, computers, televisions, energy-saving lamps, irons, refrigerators, electric welding and other equipment that has an electronic ballast system. Non-linear loads have the characteristics of causing harmonics due to the converter component in the form of a voltage rectifier that converts alternating voltage into direct voltage. The converter component is a semiconductor circuit that acts as an automatic switch in electronic circuits. Non-linear loads can also cause failures in the electrical equipment protection process, this is caused by a distorted current due to the nature of the semiconductor components in the load used. Failure of the protection causes damage to the laminate layer on the conductor. Attempts to reduce the current harmonics are done by using a passive filter, with the configuration of two types of High Pass Filter and Double Tuned Filter. Passive filter consists of a series of resistance (R), inductance (L) and capacitance (C).

In this paper, a study will be conducted on the analysis of current harmonics in a 2-storey building with an area of 80 m². The results are then simulated and used as a reference in designing the passive filters.



II. Method

This study is conducted with the following stages.

A. Flowchart of the research

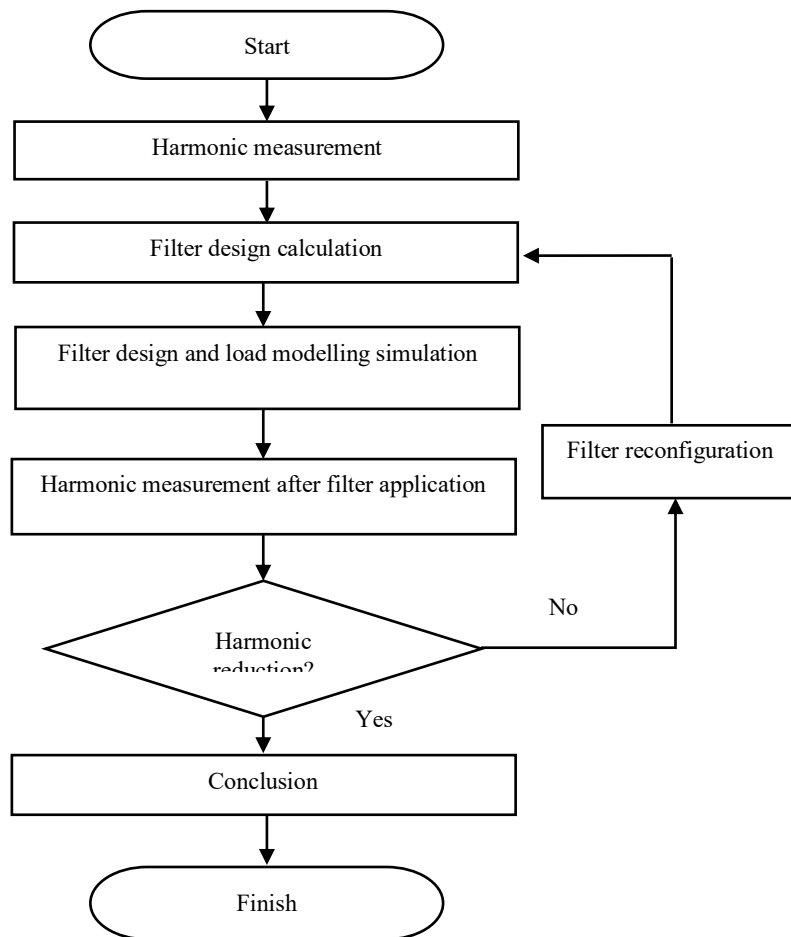

Figure 1. Research methodology

Figure 1 describes the stages of harmonic attenuation study in residential electrical installations. The first step is to measure the harmonics of current and voltage at the point of common coupling (PCC), then the value of the Total Harmonic Distortion (THD) of current and voltage will be known. The second step is to calculate and simulate the filter design that can reduce the number of harmonics based on the THD measurement data. The third step is to apply a passive filter and carry out re-measurements at the PCC point. The results of these measurements will determine if the passive filter can reduce the number of harmonics or whether it must be reconfigured.

B. Data

This study uses direct data collection method and simulation using MATLAB software. The direct data collection methods include:

- Electrical data of buildings in housing.
- Data of installed power capacity and load variables.
- Load data sheet installed.
- Configuration data of passive filter installation.

C. Data Analysis

Data analysis was carried out in several stages, including:

- a. Performing measurements of total harmonic distortion (THD) at the point of common coupling (PCC).
- b. Simulating non-linear load variables.
- c. Analyzing the value of passive filter components and harmonic attenuation.

III. Results and Discussion

From the measurement results of the point of common coupling (PCC) of electrical installations in housing area with variable of loads, the voltage harmonic values obtained are in accordance with the permissible value limits as stated in IEEE 519-1992 (shown by Table 1), while the current harmonic values exceed the permissible limits are shown in Table 2.

Table 1. Voltage harmonic measurement results (THD_v)

Main Distribution Panel	Measurement result		IEEE 519-1992 Standard		Remarks
	Voltage	THD _v (%)	Voltage	THD _v (%)	
2200VA	220 V	1,6	≤69 kV	5	As per standard

Table 2. Current harmonic measurement results (THD_i)

Main Distribution Panel	Measurement result		IEEE 519-1992 Standard		Remarks
	I _{sc} /I _L	THD _i (%)	I _{sc} /I _L	THD _i (%)	
2200VA/10A	100 – 1000	98	>1000	20	Exceeding the Standard

A. Load Variable Simulation

The non-linear load variables in the building installation are V_s = 220V; f = 50Hz. The simulation results of non-linear load modeling used in buildings are shown in Figure 2. The results of the current harmonic simulation and the harmonic spectrum are shown in Figure 3 and Figure 4, respectively.

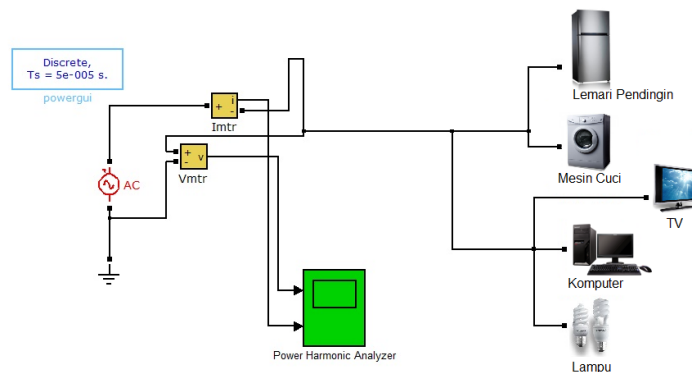

Figure 2. Non-linear loading simulation

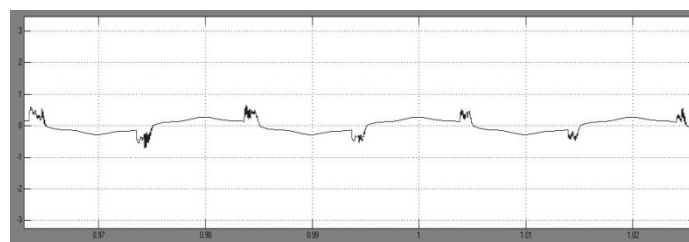

Figure 3. Current harmonic wave simulation results

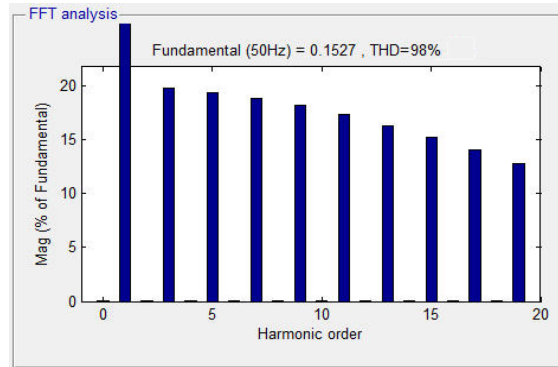

Figure 4. Current harmonic spectrum simulation results

B. Passive Filter Analysis

In order to design a passive filter, it is necessary to firstly know the total system load. The total system load is 1200W, assuming that the average load usage is 4 to 8 hours per day. The parameter values are determined as follows:

- a. It has been known that the load variable is capacitive

$$\begin{aligned}\Delta QL &= P (\tan \theta_{\text{start}} - \tan \theta_{\text{end}}) \\ &= 1200 (1,20 - 0,20) \\ &= 1200 \text{ var}\end{aligned}$$

- b. Determine the value of the inductor

$$\begin{aligned}X_L &= \frac{V^2}{\Delta QL} \\ 2 \cdot \pi \cdot f \cdot L &= \frac{V^2}{\Delta QL} \\ X_L = \frac{V^2}{\Delta QL} &= \frac{220^2}{2 \cdot (3.14) \cdot (50) \cdot (1200)} = 0,128 \text{ H}\end{aligned}$$

- c. Determine the value of the capacitor to eliminate the 3rd and 5th order, then:

$$\begin{aligned}C_{150\text{Hz}} &= \frac{1}{(2 \cdot \pi \cdot f)^2 \cdot L} = 8,8 \mu\text{F} \\ C_{250\text{Hz}} &= \frac{1}{(2 \cdot \pi \cdot f)^2 \cdot L} = 3,1 \mu\text{F} \\ C_{350\text{Hz}} &= \frac{1}{(2 \cdot \pi \cdot f)^2 \cdot L} = 1,6 \mu\text{F}\end{aligned}$$

- d. Determining the quality factor

The quality factor is determined by the variables $Q = 50$ and 80

$$R = \frac{X_0 = X_C = X_L}{50} = \frac{2 \cdot \pi \cdot f \cdot L}{50} Q = \frac{X_0}{R}$$

Table 3. Passive filter component calculation results

Filter Type	Filter Order	C	L	R
High Pass	3 (150 Hz)	8,8 μF	0,128 H	1 Ω
	5 (250 Hz)	3,1 μF	0,128 H	
Double Tuned	7 (350 Hz)	1,6 μF	0,128 H	1 Ω

C. Harmonic attenuation with passive filter

The analysis results of passive filter components calculation will previously be simulated before being applied to direct measurements in order to determine the impact of installing filters in the electrical load system used. After the addition of passive filter, the current harmonic results and spectrum are shown in Figure 4 and Figure 5, respectively. The types of filters that will be used are high pass filters and double tuned filters, which both will be configured into the system as shown in Figure 6.

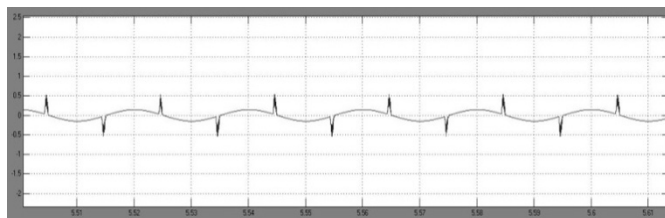

Figure 5. Current harmonic wave simulation results

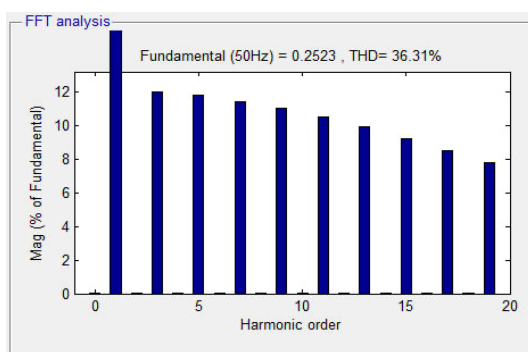

Figure 6. Current harmonic spectrum simulation results

IV. Conclusion

Based on the results of the analysis in simulations and measurements of harmonics in residential buildings, the following conclusions were obtained:

- The value of current harmonics before the installation of passive filters in residential buildings exceeds the specified standard, which is 98%. The value of voltage harmonics before the passive filter is installed according to the specified standard is 1.6%. After adding a passive filter, the value of the current harmonics decreases. The value of the current harmonics after the installation of the filter reaches the standard value of 20.89% while the value of the voltage harmonics shows a fixed value of 1.6%.
- The simulation results of non-linear load modeling in residential buildings shows that the current harmonic value exceeded the standard, which is 98%. Meanwhile, in the simulation of non-linear load modeling using a passive filter, the value of harmonics has decreased by 36.31%.

References

- [1] Ali Imran, Ahmad. 2011. "Comparison Of Several Types Of Compact Fluorescent Lamp In Terms Of Harmonic And Illumination" 16 (May)
- [2] Haskew, T.A. 1997. "Harmonic Filter Design And Installation : Case Study with Resonance" 40: 121–25.
- [3] Irianto, Chairul Gagarin, Maula Sukmawidjaja, and Aditya Wisnu. 2008. "Mengurangi Harmonisa Pada Transformator 3 Fasa" 7: 53–68.
- [4] Suweden, I Nengah, and I Wayan Rinas. 2009. "Analisa Penanggulangan THD Dengan Filter Pasif Pada Sistem Kelistrikan RSUP Sanglah" 8 (2): 7–13.
- [5] Zeng, Lingquan, and Xin Li. 2012. "Energy Procedia Research on Harmonic Suppression in Power System Based on Improved AdaptiveFilter,"1–8. doi:10.1016/j.egypro.2012.01.233.

**LEMBAR
HASIL PENILAIAN SEJAWAT SEBIDANG ATAU PEER REVIEW
KARYA ILMIAH : JURNAL ILMIAH**

Judul Jurnal Ilmiah (Artikel) : Harmonic Attenuation of Current and Voltage Using Passive Filters in Residential Electrical Installations

Penulis Jurnal Ilmiah : **Agung Herdianto**

Status Pengusul : **Penulis Mandiri / Penulis Pertama / Penulis ke.... / Penulis Korespondensi.**

Identitas Jurnal Ilmiah : a. Nama Jurnal : Jurnal Inovasi Teknologi dan Rekayasa (INOTERA)
 b. Nomor ISSN : p-ISSN: 2548-7574 e-ISSN : 2581-1274
 c. Volume/nomor, bulan, tahun : Vol.7, No.2, Juli - Desember 2022
 d. Penerbit : Politeknik Aceh Selatan
 e. DOI artikel (jika ada) : <https://doi.org/10.31572/inotera.Vol7.Iss2.2022.ID183>
 f. Alamat Web Jurnal : <https://inotera.poltas.ac.id/index.php/inotera/home>
 g. Terindeks di Scimagojr/Thomson Reuter ISI knowledge atau di **SINTA 4**

Kategori Publikasi Karya Ilmiah : Jurnal Ilmiah Internasional / Internasional Beriputasi
 (beri \checkmark pada kategori yang tepat : Jurnal Ilmiah Nasional Terakreditasi
 Jurnal Ilmiah Nasional / Nasional Terindeks di DOAJ, CABI, COPERNICUS

Hasil Penilaian Peer Review :

Komponen Yang Dinilai5)	Nilai Maksimal Jurnal Ilmiah....6)			Nilai Akhir Yang Diperoleh7)
	Internasional <input type="checkbox"/>	Nasional Terakreditasi <input checked="" type="checkbox"/>	Nasional Tidak Terakreditasi <input type="checkbox"/>	
a. Kelengkapan unsur isi artikel (10 %)		2		2
b. Ruang lingkup dan kedalaman pembahasan (30 %)		6		5,5
c. Kecukupan dan kemutakhiran data/informasi dan metodologi (30 %)		6		5
d. Kelengkapan unsur dan kualitas terbitan jurnal (30%)		6		5,5
Total = (100%)		20		18
Nilai Pengusul = (60% x 18)				10,8

Komentar Peer Reviewer

- a. Kelengkapan dan kesesuaian unsur :
 - Unsur dalam artikel sudah lengkap dan sesuai *author guidance*
 - Terdapat kesesuaian antara judul dengan isi pembahasan
 - $N = 10\% \times 20 = 2$
- b. Ruang lingkup & kedalaman pembahasan:
 - Ruang lingkup pembahasan sesuai dengan bidang keilmuan
 - Analisis pembahasan dan rujukan yang digunakan mendalam dan terdefinisi dengan jelas. Rujukan relevan dengan pembahasan
 - $N = 30\% \times 20 = 6$ menjadi 5,5
- c. Kecukupan dan kemutakhiran data/informasi dan metodologi:
 - Metode yang digunakan dalam artikel cukup jelas dan inovatif
 - Referensi yang digunakan relevan dan update 10 Tahun terakhir
 - $N = 30\% \times 20 = 6$ menjadi 5
- d. Kelengkapan unsur dan kualitas terbitan jurnal:
 - Jurnal sudah memenuhi semua unsur OJS yang baik
 - Diterbitkan di JPFK yang sudah terindeks SINTA 4
 - $N = 30\% \times 20 = 6$ menjadi 5,5
- e. Indikasi Plagiasi:
 - Tidak ada indikasi plagiasi (Plagiasi 9%)
- f. Kesesuaian bidang ilmu :
 - Terdapat kesesuaian antara bidang ilmu dengan kajian artikel

Jember, 03 November 2022

Reviewer 1,

Ismul M. Al Habib, S.Pd., M.P

NIS/NIDN.: 19821027 201109 3 022

Unit kerja : Prodi Pendidikan Biologi – FKIP

Jabatan Terakhir : Lektor

Bidang Ilmu : Pertanian

**LEMBAR
HASIL PENILAIAN SEJAWAT SEBIDANG ATAU PEER REVIEW
KARYA ILMIAH : JURNAL ILMIAH**

Judul Jurnal Ilmiah (Artikel) : Harmonic Attenuation of Current and Voltage Using Passive Filters in Residential Electrical Installations

Penulis Jurnal Ilmiah : **Agung Herdianto, S.T., M.T**

Status Pengusul : **Penulis Mandiri / Penulis Pertama / Penulis ke.... / Penulis Korespondensi.**

Identitas Jurnal Ilmiah : a. Nama Jurnal : Jurnal Inovasi Teknologi dan Rekayasa (INOTERA)
 b. Nomor ISSN : p-ISSN: 2548-7574 e-ISSN : 2581-1274
 c. Volume/nomor, bulan, tahun : Vol.7, No.2, Juli - Desember 2022
 d. Penerbit : Politeknik Aceh Selatan
 e. DOI artikel (jika ada) : <https://doi.org/10.31572/inotera.Vol7.Iss2.2022.ID183>
 f. Alamat Web Jurnal : <https://inotera.poltas.ac.id/index.php/inotera/home>
 g. Terindeks di Scimagoir/Thomson Reuter ISI knowledge atau di **SINTA 4**

Kategori Publikasi Karya Ilmiah : Jurnal Ilmiah Internasional / Internasional Beriputasi
 (beri \checkmark pada kategori yang tepat : Jurnal Ilmiah Nasional Terakreditasi
 Jurnal Ilmiah Nasional / Nasional Terindeks di DOAJ, CABI, COPERNICUS

Hasil Penilaian Peer Review :

Komponen Yang Dinilai5)	Nilai Maksimal Jurnal Ilmiah....6)			Nilai Akhir Yang Diperoleh7)
	Internasional <input type="checkbox"/>	Nasional Terakreditasi <input checked="" type="checkbox"/>	Nasional Tidak Terakreditasi <input type="checkbox"/>	
a. Kelengkapan unsur isi artikel (10 %)		2		1,8
b. Ruang lingkup dan kedalaman pembahasan (30 %)		6		5,2
c. Kecukupan dan kemutakhiran data/informasi dan metodologi (30 %)		6		5,5
d. Kelengkapan unsur dan kualitas terbitan jurnal (30%)		6		5
Total = (100%)		20		17,5
Nilai Pengusul = (60% x 17)				10,5

Komentar Peer Reviewer

- a. Kelengkapan dan kesesuaian unsur :
 - Sistematika penulisan sudah sesuai dengan template jurnal
 - Terdapat kesesuaian benang merah antara judul dengan pembahasan
 - **N = 10% x 20 = 2 menjadi 1,8**
- b. Ruang lingkup & kedalaman pembahasan:
 - Pembahasan sesuai dengan ruang lingkup penelitian
 - Analisis dan rujukan yang digunakan cukup jelas dan sesuai
 - **N = 30% x 20 = 6 menjadi 5,2**
- c. Kecukupan dan kemutakhiran data/informasi dan metodologi:
 - Kebaruan referensi sudah 10 Tahun terakhir dan relevan
 - Metodologi yang digunakan cukup jelas dan ada unsur novelty
 - **N = 30% x 20 = 6 menjadi 5,5**
- d. Kelengkapan unsur dan kualitas terbitan jurnal:
 - Artikel diterbitkan pada jurnal terakreditasi SINTA 4
 - Secara umum jurnal sudah lengkap dan sesuai
 - **N = 30% x 20 = 6 menjadi 5**
- e. Indikasi Plagiasi:
 - Plagiasi dibawah 25% sesuai panduan terbitan jurnal
- f. Kesesuaian bidang ilmu :
 - Terdapat kesesuaian bidang ilmu dengan artikel

Jember, 03 November 2022

Reviewer 2,

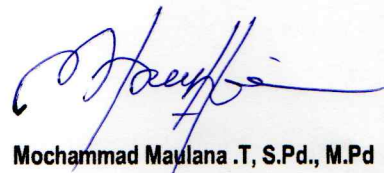

Mochammad Maulana .T, S.Pd., M.Pd

NIS/NIDN.: 19910409 201604 3 248

Unit kerja : Prodi PAUD

Jabatan Terakhir : Asisten Ahli

Bidang Ilmu : Pendidikan IPA